

LTE-Advanced

Three Technologies and Two Proposals

Cambise Homayounfar
CEO
PHYBIT, INC.

29 September 2008

Presentation Overview

LTE-Advanced Requirements

Three Candidates for 1 Gbps Mobile Wireless

1. Lowpower Metric for MiMo; MCD
2. Stochastic AMC; SAMC
3. LDPC Convolutional Codes; LDPC-CC

Two Implementation Proposals

1. Lowpower MiMo ASIC
 - 1 Gbps QRM-MLD with MCD
2. Channel Decoder ASIC
 - 1 Gbps LDPC-CC with SAMC

LTE-Advanced

Requirements

The goals of LTE-Advanced are higher data rates and spectral efficiency

Spectral Efficiency [bps/Hz]

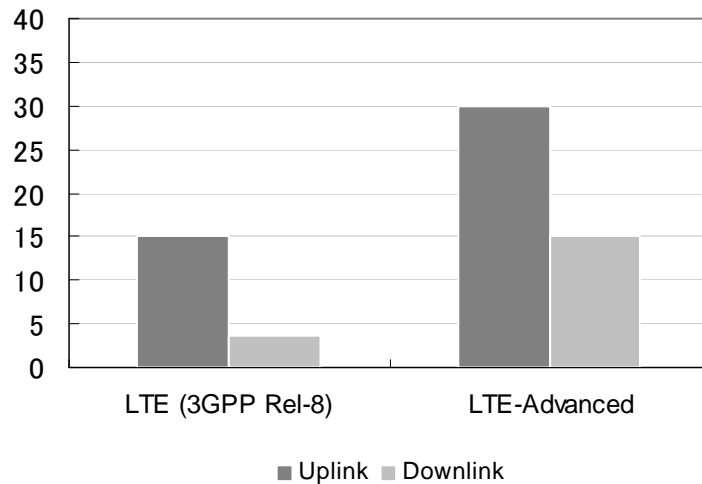

Max Data Rates [Mbps]

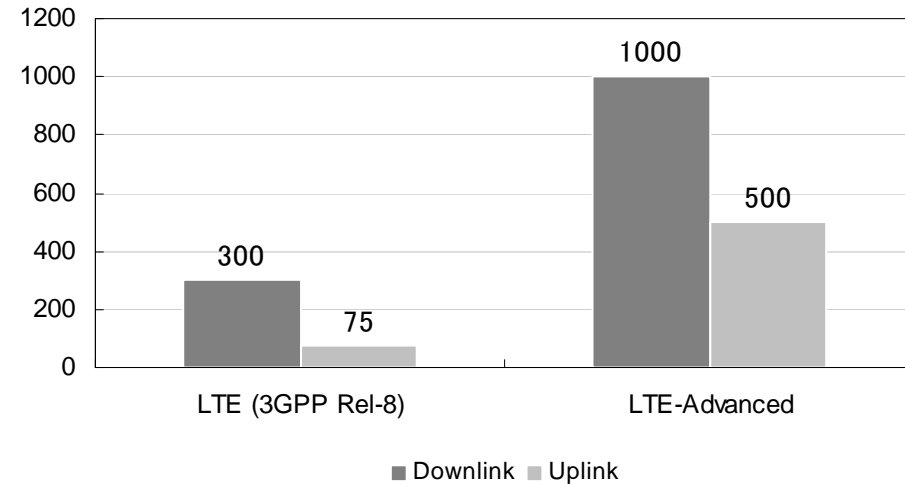

What kind of technologies are useful for LTE-Advanced?

Enabling Technology	Phybit Activity
Higher-Order MiMo	Lowpower MiMo Metric
Adaptive Modulation and Coding (AMC)	Stochastic AMC
Advanced Channel Coding	LDPC Convolutional Codes

Lowpower MiMo Metric

Lowpower MiMo Metric

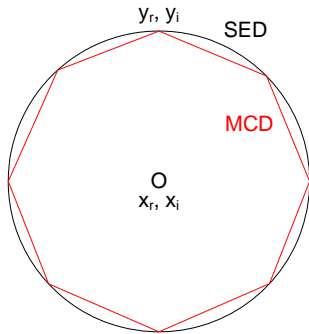

There are many MiMO algorithms

Almost all use Squared Euclidean Distance (SED)

$$L_2 = (x_r - y_r)^2 + (x_i - y_i)^2 \tag{EQ 1}$$

Phybit proposes a new metric;

$$L_1^\infty = \frac{1}{2}(L_1 + L_\infty) \tag{EQ 2}$$

We call this Manhattan-Chebyshev Distance, or simply MCD

- MCD is an average of Manhattan $L_1 = |x_r - y_r| + |x_i - y_i|$ and Chebyshev $L^\infty = \max(|x_r - y_r|, |x_i - y_i|)$ distances

MCD works very well for VLSI implementation of MiMo algorithms

- MCD power consumption is 90% lower than SED
- MCD logic circuit is 75% smaller than SED

QRM-MLD with MCD

We used MCD in QRM-MLD

- BER performance is very similar
- Almost the same for $E_b/N_0 < 7$ dB

Results show

- Coded performance (Turbo codes)
- Uncoded performance

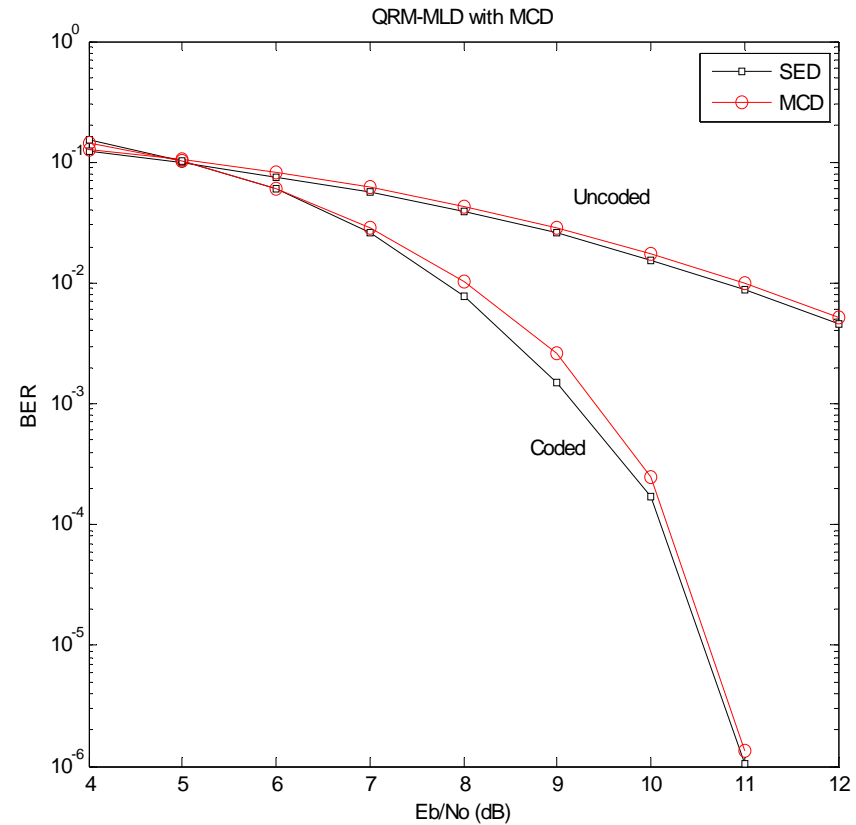

Other MiMo with MCD

We used MCD in another MiMo

- B-Chase MiMo
- Again, BER performance is very similar
- No turbo decoding was used

Conclusion

- MCD works well with QRM-MLD and B-Chase

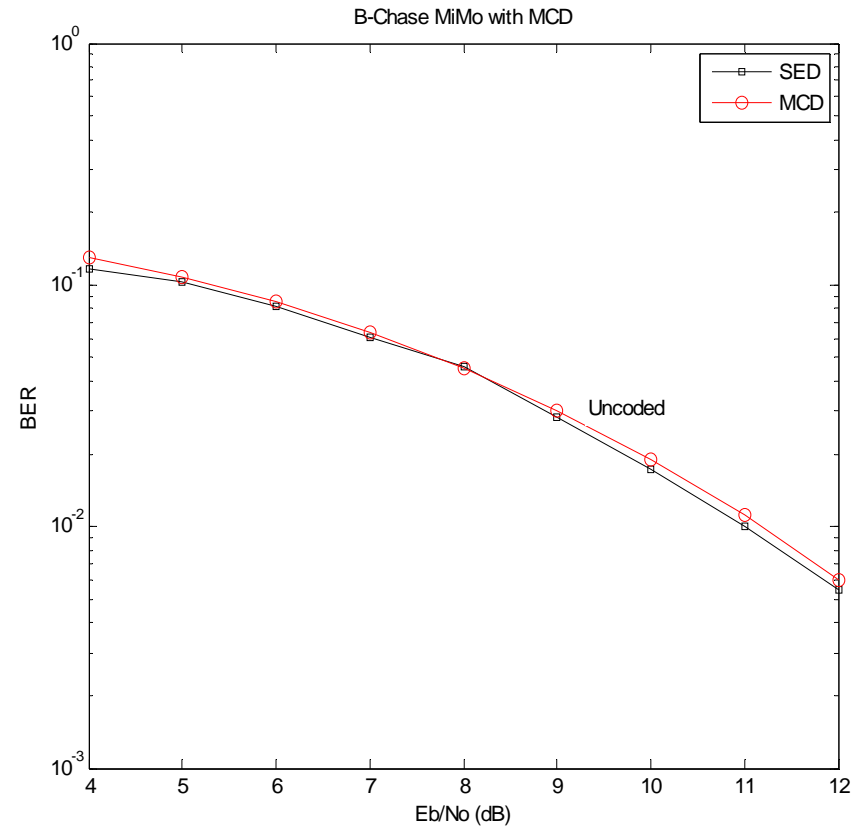

Accuracy of MCD

Why MCD works so well?

- Because it is quite accurate
- Its maximum error is about 10%
- Manhattan maximum error is 40%
- Chebyshev maximum error is 30%

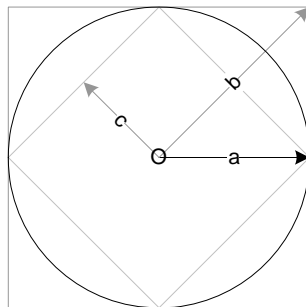

a; Euclidean Distance
 b; Manhattan Distance
 c; Chebyshev Distance

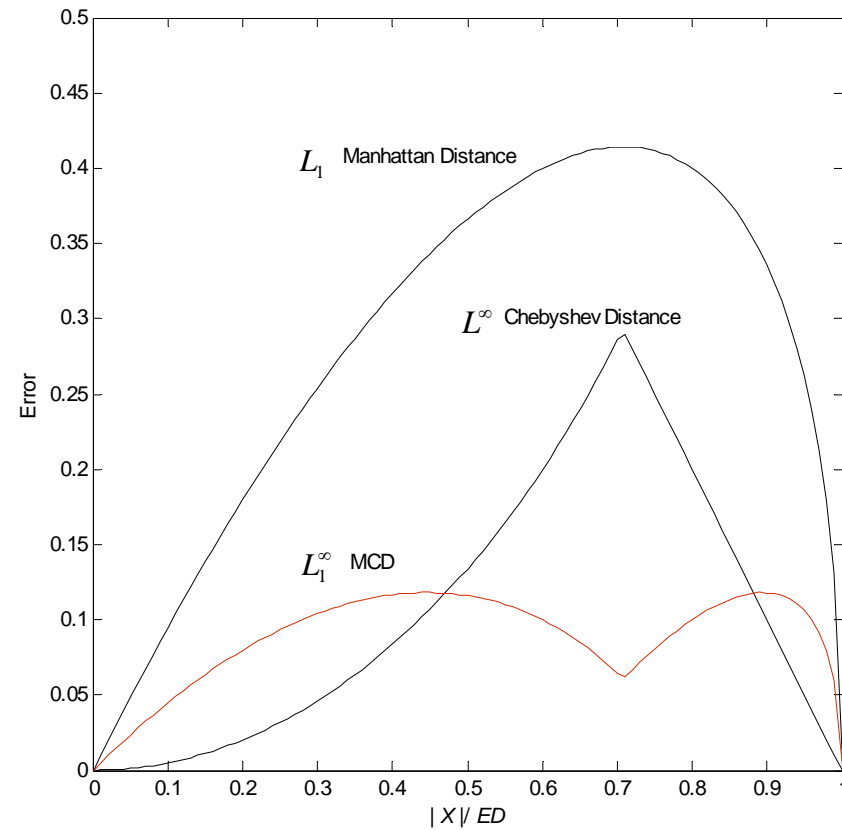

Power and Area of MCD

The MCD Advantage

- MCD power consumption is 90% lower than SED
- MCD circuit area is 75% smaller than SED

Metric	Adder/Subtractor	Multiplier	Comparator	Multiplexer
SED	Two 8-bit sub One 16-bit add	Two 8-bit mpy		
MCD	Two 8-bit sub with abs Two 8-bit add		One 8-bit	One 2-to-1

	Adder/Subtractor		Multiplier	Comparator	Multiplexer
	8-bit	16-bit	8-bit	8-bit	8-bit
Power	1.79 μ W	4.47 μ W	28.2 μ W	1.54 μ W	0.643 μ W
Area	1.44 μ m ²	3.024 μ m ²	12.951 μ m ²	0.837 μ m ²	0.792 μ m ²

90 nm 6ML TSMC Proceed; Synthesis Estimates

Metric	Power	Area
SED Circuit	64.45 μ W	31.806 μ m ²
MCD Circuit	6.343 μ W	7.389 μ m ²

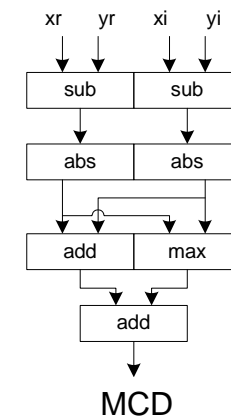
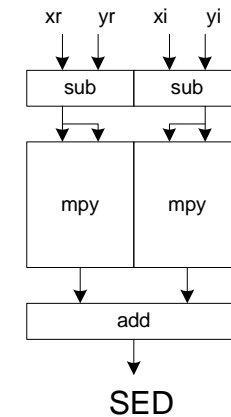

How MCD Helps QRM-MLD

SED is 95% of QRM-MLD computation

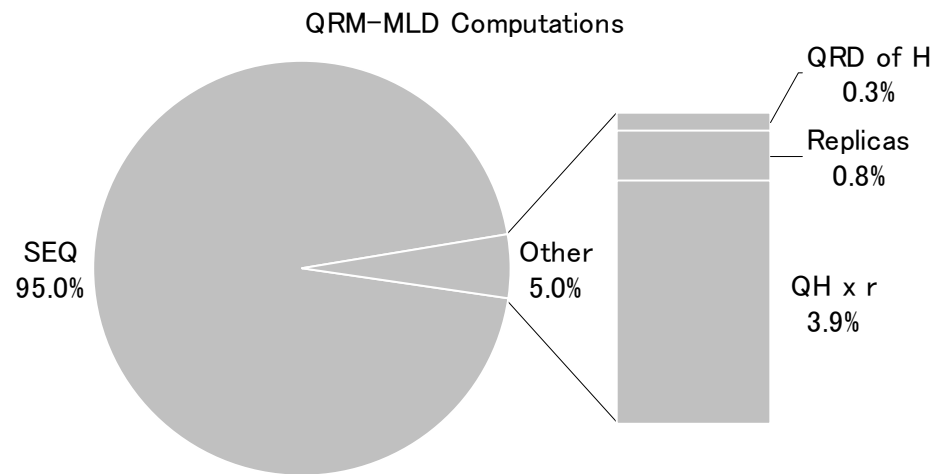

It is possible to reduce this by MCD

- SED by lookup table is also possible, but memory size becomes large

Implementation Proposal 1

Phybit can deliver a Lowpower QRM-MLD ASIC with MCD

- We propose a three phase project

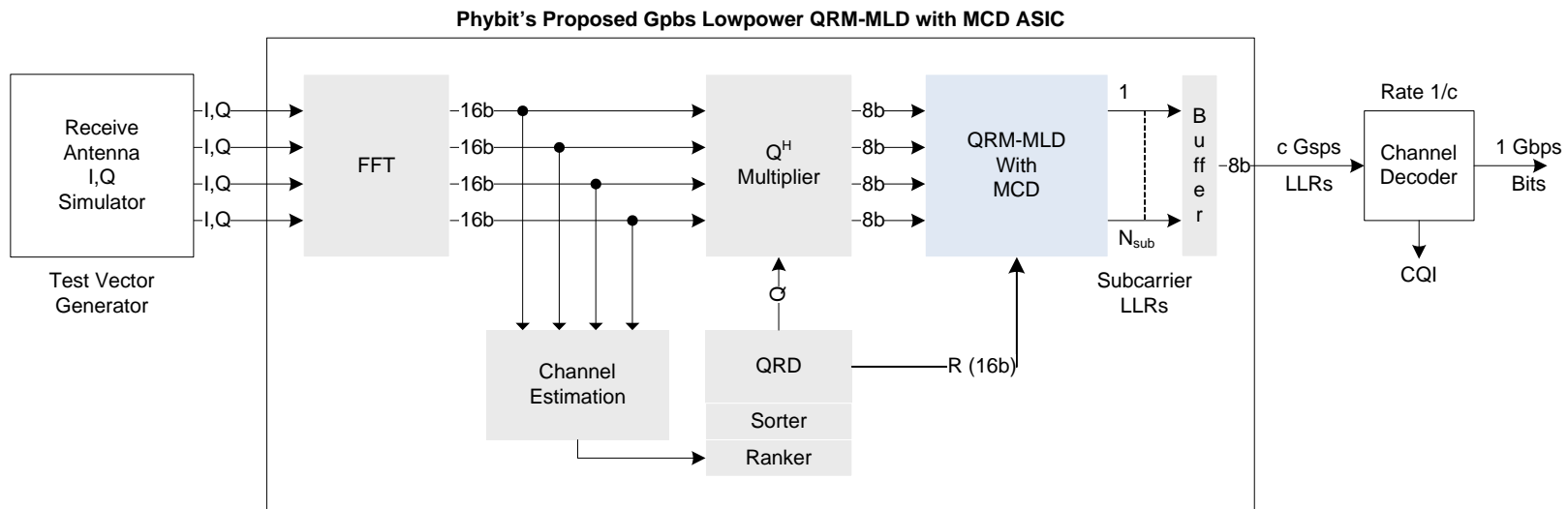
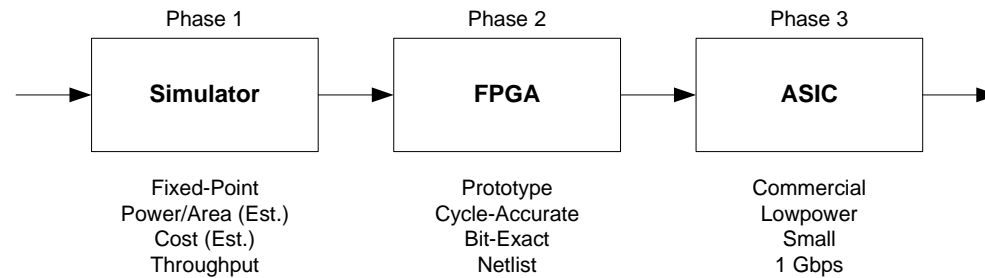

Stochastic AMC

Stochastic AMC

SAMC is a mixture of two techniques:

- Instantaneous Estimation of Bit Error Probability
- Statistical Quality Control SQC

BEP is estimated from channel decoder

- We map Log-Likelihood Ratio (LLR) to BEP

SQC is simple and effective quality control

- If BEP is below the QoS Target, make no change
- Otherwise, adapt the modulation and channel coding

SQC follows a proven maxim of quality

- When it is not necessary to change, it is necessary not to change

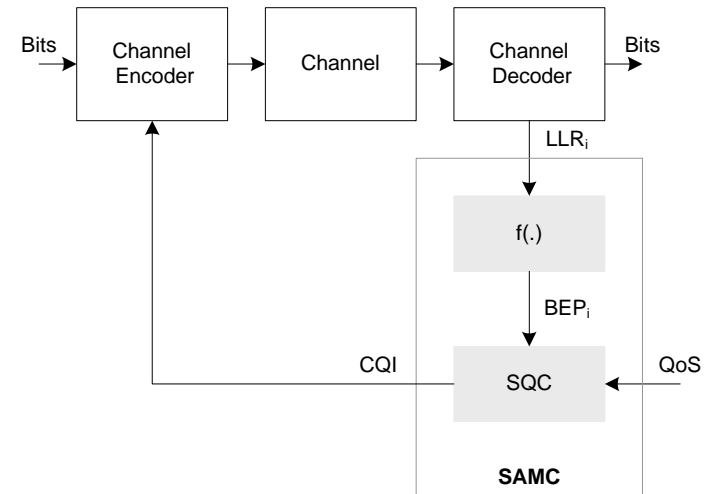

How SAMC works?

SAMC consider the radio channel as a stochastic process

- For good channels, BEP is a stationary process
- For bad channels, BEP becomes a non-stationary process

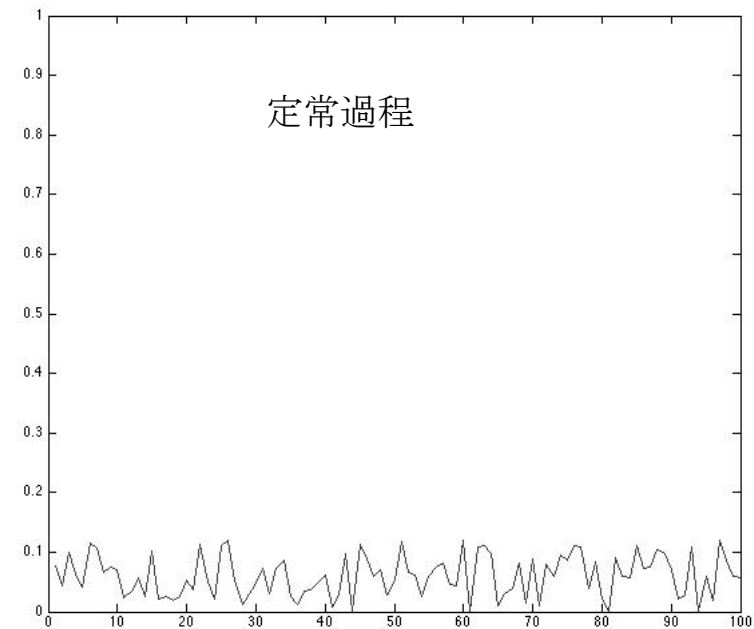
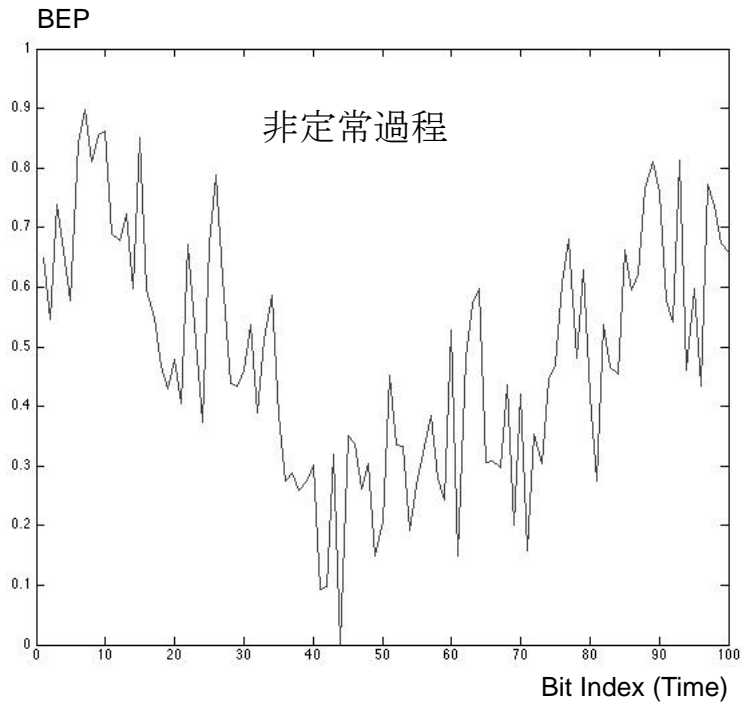

SAMC and CQI

Channel Quality Indicator (CQI) changes the rate

The decision to change modulation/coding is based on two limits

- Warning Limit: process is becoming non-stationary
- Action Limit: process is already non-stationary

Two rules determine the value of Channel Quality Indicator (CQI)

1. If BEP exceeds the Warning Limit;
 - Modulation/coding rate changes by a small step
2. If BEP exceeds the Action Limit;
 - Modulation/coding rate changes by a large step

Combination of BEP and SQC make up SAMC

- SAMC provides a clear framework for determination of CQI
- Other AMC algorithms use empirical approaches

SAMC for VoIP over HSPA

Description

We used SAMC for VoIP over HSPA

Advantage: Erlang capacity can be doubled with even better QoS

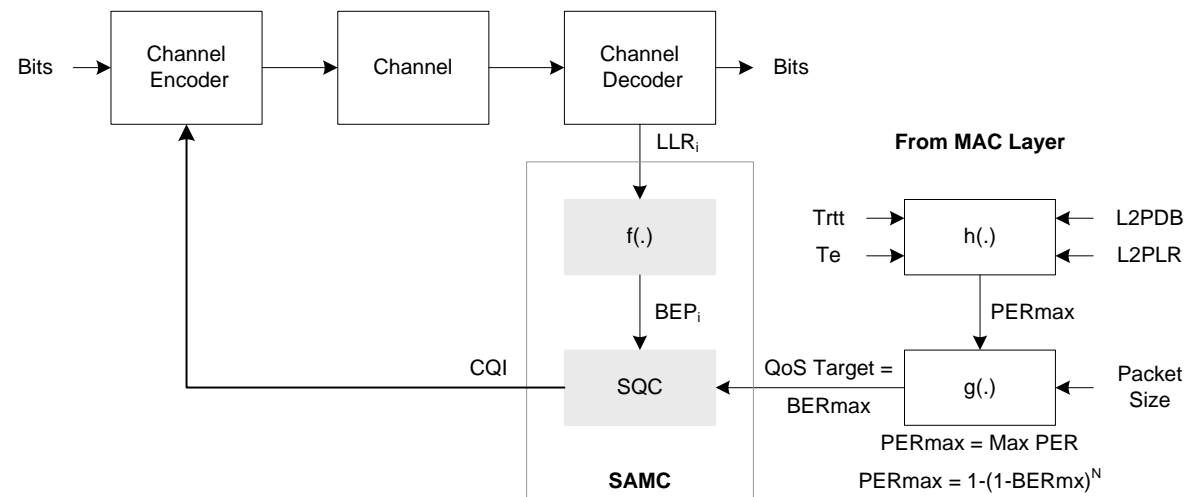

Our SAMC algorithm uses Layer 2 QoS parameters

- L2 Packet Data Budget (L2PDB) and L2 Packet Loss Rate (L2PLR)
- Trtt = Round-trip time from packet arrival at PDCP to P-GW
- Te = Elapsed time while packet waits to be sent

SAMC for VoIP over HSPA

Performance

SAMC doubles the sector capacity in Erlangs with one receiver

- With diversity receivers, we expect even better performance.

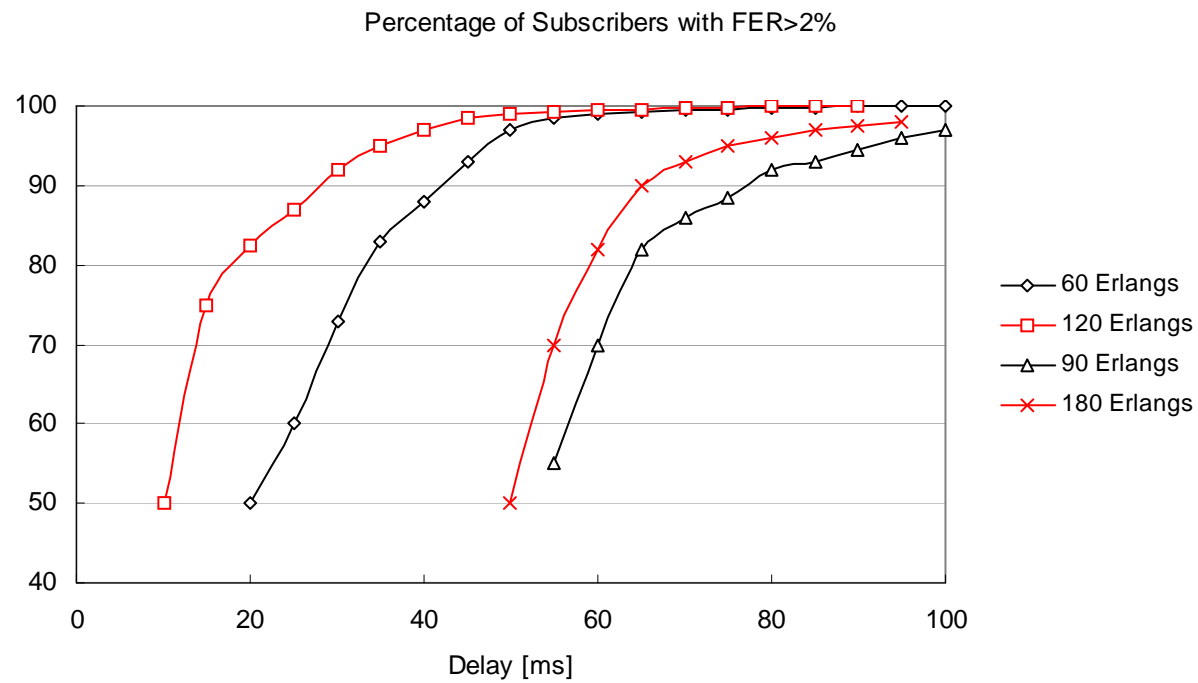

LDPC Convolutional Codes

LDPC Convolutional Codes

LTE-Advanced needs excellent spectral efficiency

- 30 bps/Hz for downlink and 15 bps/Hz uplink
- MiMo is one way to reach this efficiency
- Another way is through channel coding

AMC needs variable-rate coding

Variable-rate turbo codes are not easy

- Interleaving becomes complex
- LDPC is another candidate
- Needs no interleaving

But variable-rate LDPC is also difficult

- Parity Check Matrix must change for every rate

Features of LDPC-CC

There are two kinds of LDPC codes:

1. LDPC Block Codes (LDPC-BC)
2. LDPC Convolutional Codes (LDPC-CC)

LDPC-CC performance depends on its memory

- Memory size of 128 is typical: Compare this to 7 to 9 for CC

LDPC-BC performance depends on block size

- Ranges from 2000 to 200,000 bits

So LDPC-CC are in fact really powerful CCs

- They can be decoded by similar algorithms to LDPC-BC
- Much room for parallelism

We hope LDPC-CC can be considered for LTE-Advanced

Performance of LDPC-CC

Higher memory (2048) improves performance

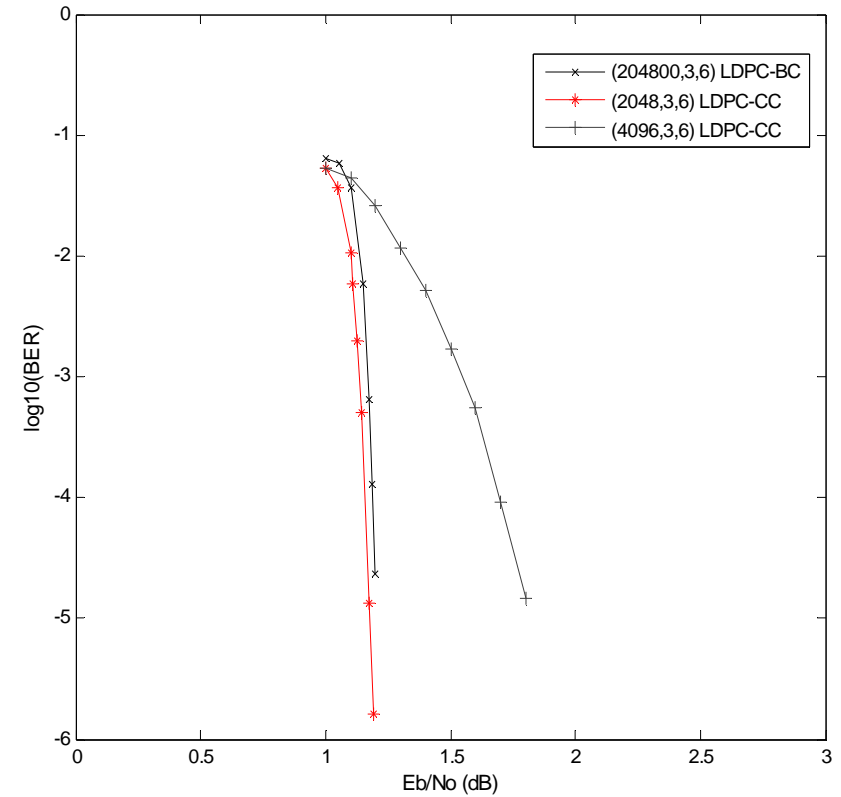
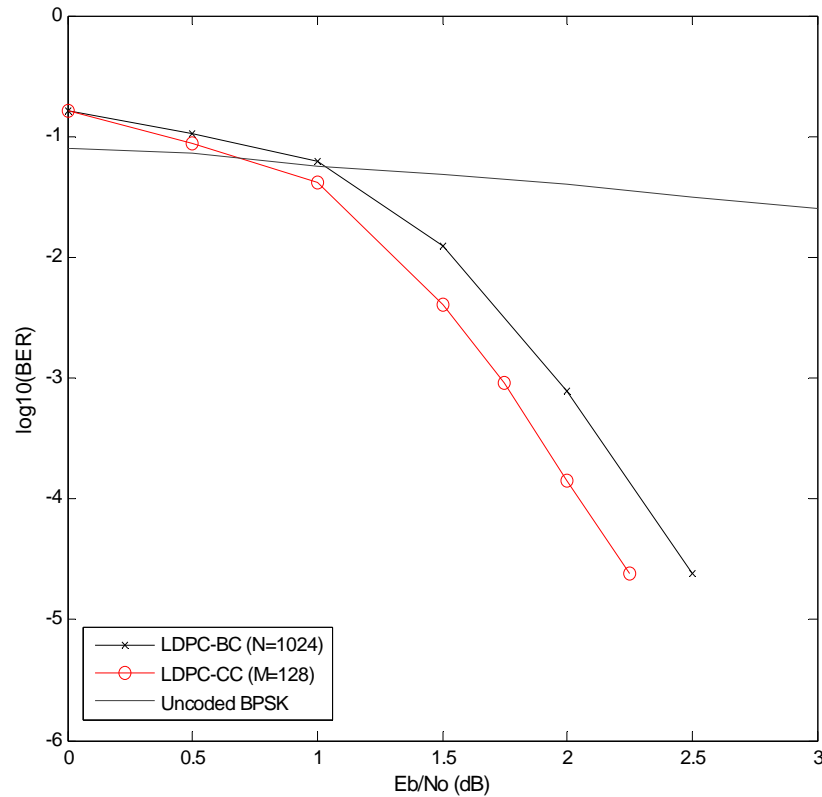

Implementation Proposal 2

Three-Phase development of LDPC-CC with SAMC ASIC

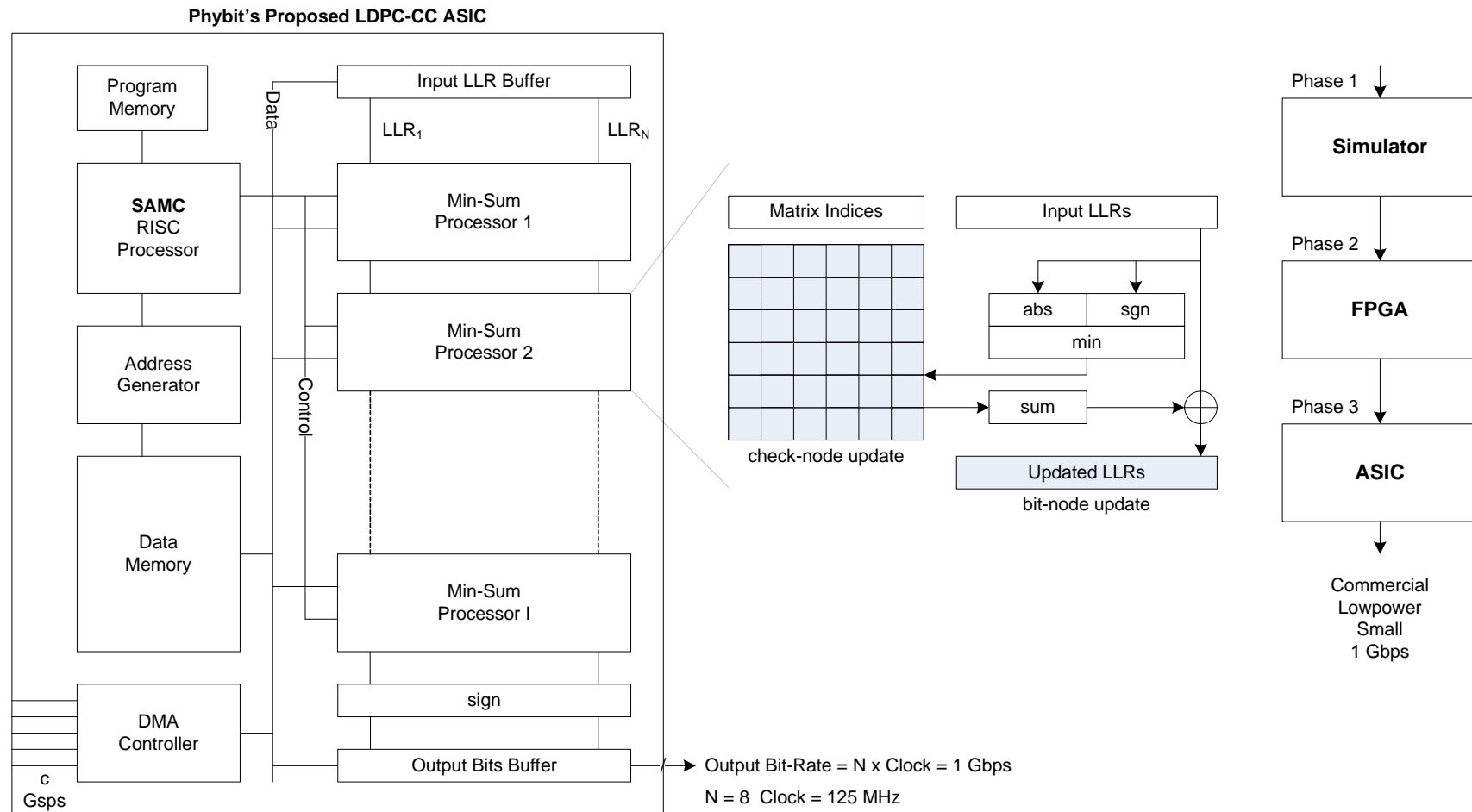

Summary and Conclusions

Summary

Phybit presented three technologies today

1. Low-power MiMo Metric; MCD
2. Stochastic AMC; SAMC
3. LDPC Convolutional Codes

Phybit described two Implementation Proposals

1. 1 Gbps QRM-MLD with MCD ASIC
2. 1 Gbps LDPC-CC with SAMC

We hope these could be useful for LTE-Advanced

- If this technology interests you, please work with us
- Please consider our Implementation Proposals 1 and 2
- Any other information will be gladly given
- Other project ideas are welcome
- We will follow your directions